

PLAN VIEW
SCALE (DNS)

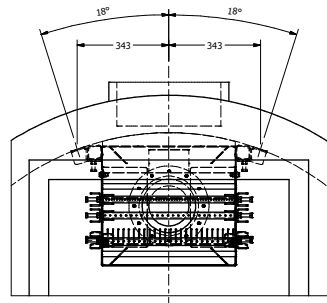

DETAIL A
WALL FIXING LOCATION DETAIL
ACCESS LID NOT SHOWN FOR CLARITY
SCALE (DNS)

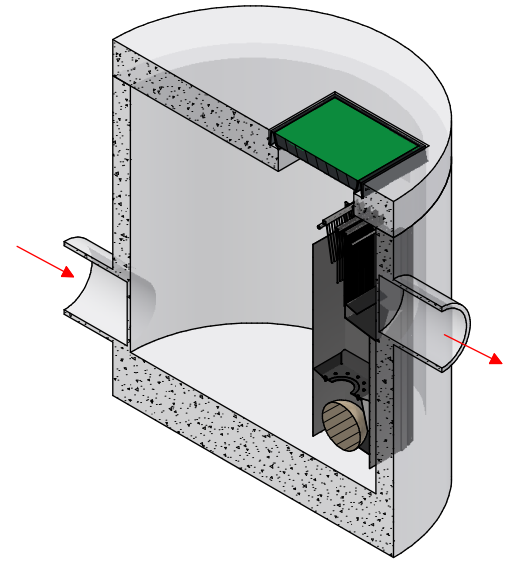

SECTION VIEW ISOMETRIC
SCALE (DNS)

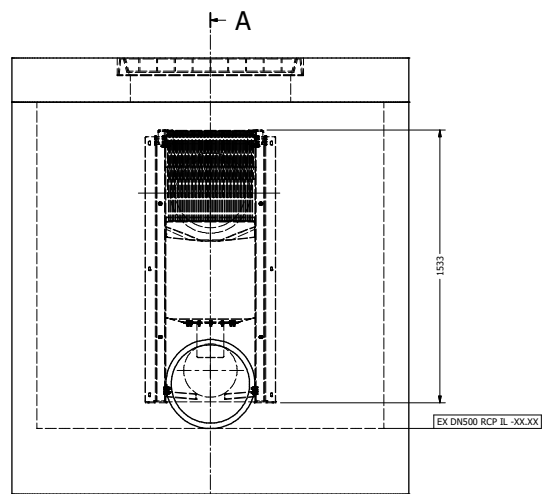

FRONT ELEVATION
SCALE (DNS)

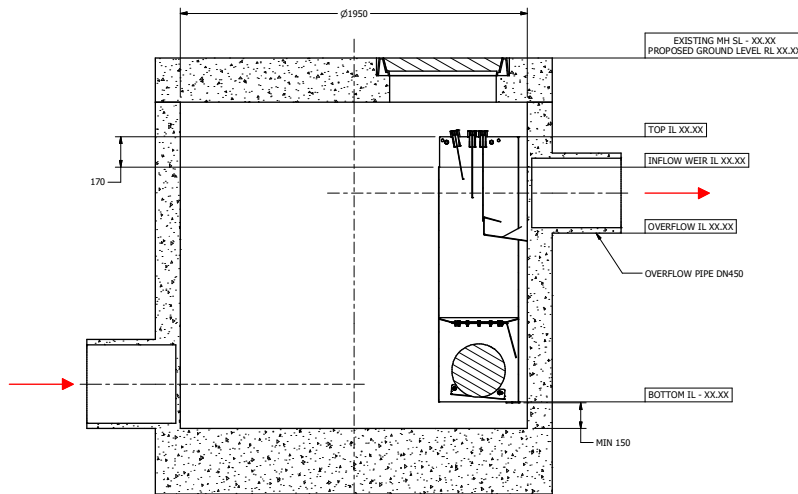

SECTION A-A
SCALE (DNS)

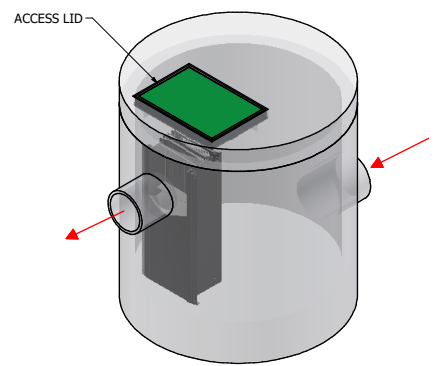

ISOMETRIC VIEW
SCALE (DNS)

REV	DESCRIPTION	BY	CKD	APP	DATE
A	GENERAL ARRANGEMENT - ISSUED FOR INFORMATION ONLY	BC	DD	DD	5/12/2022

REVISION HISTORY

DRAPPER ENVIRONMENTAL CONSULTANTS

13147 BOUNDARY ROAD
WINDY HILLS VIC 3084
PH: 03 9450 1234
WWW.DRAPERENVIRONMENTAL.COM.AU
EMAIL: SALES@DRAPERENVIRONMENTAL.COM.AU

GENERAL NOTES

1. CONSULT WITH THE DESIGNER REGARDING ALL ASPECTS OF THE DESIGN AND CONSTRUCTION. A LID IS NOT TO BE CONSIDERED AS A PART OF THE DESIGN UNLESS SPECIFICALLY NOTED OTHERWISE. THE DESIGNER SHALL BE RESPONSIBLE FOR THE PROVISION OF ALL NECESSARY INFORMATION.

2. THIS DRAWING AND THE DESIGN SHOWN HEREIN REMAINS THE PROPERTY OF DRAPPER ENVIRONMENTAL CONSULTANTS AND SHALL NOT BE ALTERED, COPIED OR REPRODUCED IN PART OR IN WHOLE IN ANY FORM WITHOUT THE WRITTEN PERMISSION OF DRAPPER ENVIRONMENTAL CONSULTANTS AND SHALL BE USED ONLY BY THE CLIENT OF DRAPPER ENVIRONMENTAL CONSULTANTS FOR THE PROJECT FOR WHICH IT WAS PROVIDED.

TITLE: **WATSOL Ø1950 PIT GENERAL ARRANGEMENT**

CLIENT: _____

PROJ REF: _____

DRAWING No: **STD-WAT-1950RND**

DRAWN: BC DATE: 13.1.22

DSGD: DD APP: DD

CKD: DD APP DATE: 5/12/2022

SHEET: 1 OF 1

SCALE: **DNS**

REV: A A1