



Form 04584447  
Edition 1  
November 2004

# Air Impact Wrench

2934B and 2940B

---

## Parts Information



**Save These Instructions**

***IR*** Ingersoll-Rand®

**2934B and 2940B Air Impact Wrench Exploded Diagram**

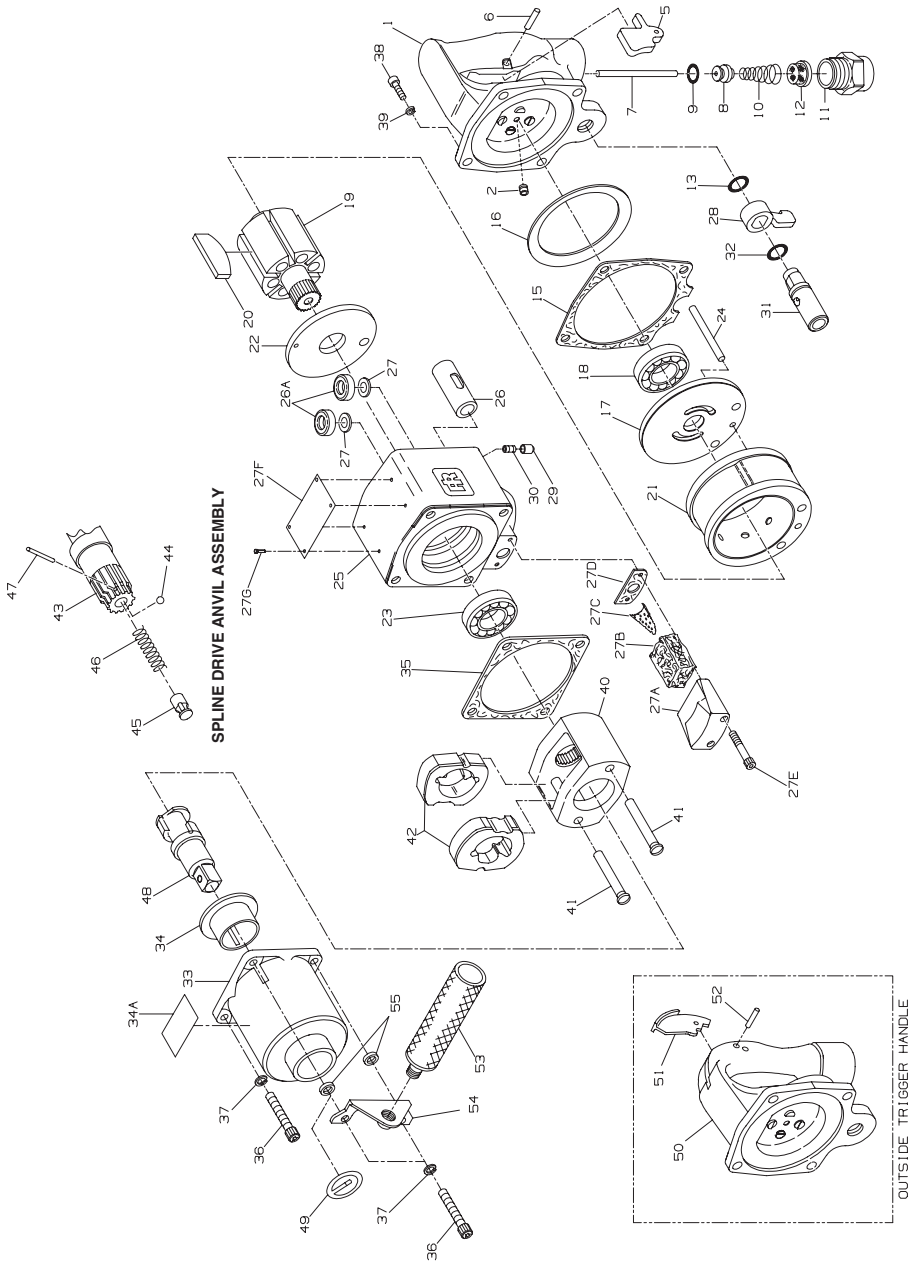

(Dwg. TPA1333-3)

## 2934B and 2940B Air Impact Wrench Parts List

Item	Part Description	Part Number	Item	Part Description	Part Number
1	Inside Trigger Handle Assembly	2934-A92A	*	Oversize Hammer Case Bushing	
2	Grease Fitting	130SR-188		.005" oversize	293-641-5
5	Trigger	834-93A		.010" oversize	2934-641-10
6	Trigger Pin	534-265		.015" oversize	2934-641-15
7	Throttle Valve Plunger	2934-302	† 35	Hammer Case Gasket	2934-36
8	Throttle Valve Assembly	2934-A50	36	Hammer Case Cap Screw (4)	834-638
† 9	Throttle Valve Face	2934-159	37	Hammer Case Cap Screw Lock Washer (4)	34U-58
† 10	Throttle Valve Spring	834-51	38	Handle Cap Screw (4)	510-638
11	Straight Inlet	845-565	39	Handle Cap Screw Lock Washer (4)	8U-58
† 12	Air Strainer Screen	434-61	40	Hammer Frame Assembly	
† 13	Reverse Valve Seal	R00BR-210		for 2934B	2934-A703
† 15	Handle Gasket	2934-283		for 2940B	2940-A703
16	Motor Clamp Washer	2934-207	41	Hammer Pin (2)	
17	Rear End Plate	2934-12		for 2934B	2934-704
† 18	Rear Rotor Bearing	508-97		for 2940B	2940-704
19	Rotor		42	Hammer (2)	
	for 2934B	2934-53		for 2934B	2934-724
	for 2940B	2940-53		for 2940B	2940-724
† 20	Vane Packet (set of 6 Vanes)		43	Spline Drive Anvil Assembly	
	for 2934B	2934-42-6		for 2934B	2934-A526
	for 2940B	2940-42-6		for 2940B	2940-A526
21	Cylinder		44	Socket Retaining Ball	D04-280
	for 2934B	2934-3	45	Retaining Ball Plunger	845-230
	for 2940B	2940-3	46	Retaining Plunger Spring	2940-231
22	Front End Plate	2934-11	47	Plunger Retaining Pin	845-128
† 23	Front Rotor Bearing	810-97	48	1" Square Drive Anvil Standard Length	
24	Cylinder Dowel			for 2934B	2934-726
	for 2934B	2934-98		for 2940B	2940-726
	for 2940B	2940-98		6" Extended Length	
25	Motor Housing Assembly			for 2934B	2934-314-6
	for 2934B	2934-A40A		for 2940B	2940-314-6
	for 2940B	2940-A40	49	Socket Retainer	RR10015S
26	Reverse Valve Bushing	2934-330S	50	Outside Trigger Handle Assembly	2934-A1
† 26A	Air Port Gasket (2)	R44H-210A	51	Trigger	844-78
† 27	Air Port Gasket Retainer (2)	2940-200	52	Trigger Pin	F02-15
27A	Exhaust Deflector	2934-23A		Also includes illustrated parts 2, 7, 8, 9, 10, 11, 12, and 13	---
† 27B	Exhaust Silencer	2940P-311	53	Dead Handle	834-48
27C	Exhaust Baffle	2934-124	54	Dead Handle Bracket	2934-364
27D	Exhaust Gasket	2934-223	55	Dead Handle Bracket Spacer (2)	2934-140
27E	Deflector Screw (2)	R43F-104	*	Horizontal Hanger	2934-366
27F	Nameplate		*	Horizontal Hanger Spacer (2)	2934-140
	for 2934B	2934-301	*	Side Spade Handle	T15-41
	for 2940B	2940-301	*	Side Spade Handle Stud	534-448
27G	Nameplate Screw (4)	C32-302	*	Side Spade Handle Stud Nut	107-73A
28	Reverse Lever	2934-658A	*	Grease Gun	R000A2-228
† 29	Reverse Lock Plunger	4U-663B	*	Tune-up Kit (includes illustrated parts 3, 9, 10, 12, 13, 15, 18, 20, 23, 26A [2], 27 [2], 27B, 29, 30, 32 and 35)	
† 30	Reverse Lock Plunger Spring	4U-664		for 2934B	2934-TK3
31	Reverse Valve Assembly	2934-A329		for 2940B	2940-TK3
† 32	Reverse Valve Bushing Seal	85H-167	*	Exhaust Deflector Kit (includes illustrated parts 27A thru 27E)	2934-K23
33	Hammer Case Assembly				
	for 2934B	2934-A727			
	for 2940B	2940-A727			
34	Hammer Case Bushing	2934-641			
34A	Hammer Case Label				
	for 2934B and 2940B	WARNING-2-99			

\* Not illustrated.

† Indicates Tune-up Kit part.

• To keep downtime to a minimum, it is desirable to have on hand certain repair parts. We recommend that you stock one (pair or set) of each part indicated by a bullet (\*) for every four tools in service.

