



*Rupture Disc Assembly with Pressure Gauge  
Installed Between 3-Way Valve and Pressure Relief Valve*

## INTRODUCTION

Hansen rupture disc assemblies (RDAs) are used to indicate which pressure-relief valve has discharged. A pressure-relief valve will re-seat after discharging. However, a rupture disc remains open after bursting. (A rupture disc is not a stand alone safety device.) An installed pressure gauge or switch (required by code) provides a visual or electronic indication that the rupture disc has burst. Also, rupture disc assemblies provide a hermetic seal to help eliminate any possibility of minute losses of refrigerant via pressure-relief valve seat materials.

Hansen rupture disc assemblies are designed with a double-weld construction. There are no gaskets to leak. The rupture disc inside the assembly is patented hermetically welded to the body and mechanically isolated from any pipe stress. A separate body weld seals the assembly. This design helps eliminate internal and external leaks and ensures that the disc will burst at its design pressure.

## TYPICAL APPLICATION

These rupture disc assemblies are typically used between a vessel (or 3-way valve) and a pressure-relief valve. They must be used for atmospheric, not differential, pressure relief. Rupture disc assemblies are required when using Hansen pressure-relief valves for halocarbon applications because the high cost of such refrigerants demands extreme tightness.

## Specifications, Applications, Service Instructions & Parts

### RUPTURE DISC ASSEMBLIES, GAUGES AND PRESSURE SWITCHES

**For Industrial Ammonia and  
Large Commercial or  
Industrial Halocarbon  
Refrigeration Systems**

## KEY FEATURES

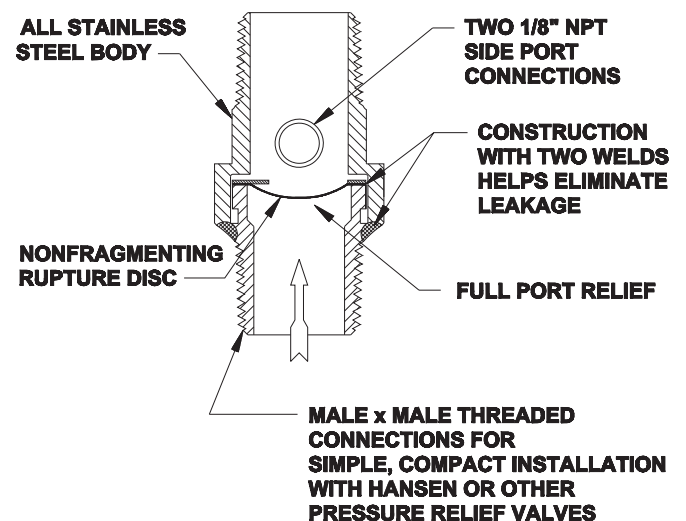

## ASME RULES

In accordance with ASME code, a pressure gauge, or pressure switch must be connected to the space between the rupture disc and the connected pressure-relief valve to enable detection. Two 1/8" NPT side ports are provided in Hansen's rupture disc assemblies for this purpose.

When a rupture disc assembly is installed with a pressure-relief valve, the stamped capacity of the pressure-relief valve must be reduced 10% for sizing purposes.

## SPECIFICATIONS

Body: Stainless Steel

Rupture disc:

1/2" and 3/4" 316 Stainless Steel

1" and 1 1/4" Nickel

Refrigerant temperature: -60°F to +240°F (-51°C to +115°C)

Disc ambient temperature: Between 32°F and 125°F (0°C and 52°C) the nominal burst pressure is within 2% of the pressure stamped on the rupture disc assembly body. At lower temperatures, the burst pressure will be slightly higher. Contact Hansen Technologies directly for specific applications.

Safe working pressure (body): 400 psig (28 bar)

For ammonia, R22, R134a, and other Hansen approved refrigerants

## INSTALLATION

When installing these rupture disc assemblies, ensure that the threads are clean. Use suitable thread sealer being certain that none gets inside the rupture disc assembly or connected pressure-relief valve. Do not touch the internal rupture disc with tools, fingers, or other items. If unused, the 1/8" side port must be plugged.

Make sure that the rupture disc assembly is installed in the proper direction. The arrow stamped on the body of the rupture disc assembly should point in the direction of flow, from the vessel to the pressure-relief valve. This ensures that the disc will burst at its design pressure and ensures proper operation of the installed pressure gauge and switch.

Make certain that the rupture disc assembly is installed tightly. Check for leaks before placing the assembly in service.

## IMPORTANT

Users are warned that a rupture disc will not burst at its design pressure if back pressure builds up in the space between the disc and that pressure relief valve. This could occur should leakage develop in the rupture disc due to corrosion creep and fatigue, or physical damage. **There is no guarantee of rupture disc life. Therefore, routinely check for the presence of pressure between the rupture disc and relief valve to ensure that no leakage or rupture has occurred. If leakage is discovered at any time, replace as soon as possible.**

There are no user-serviceable parts in the rupture disc assembly, pressure gauge, or pressure switch. If the gauge or switch indicates "burst," the rupture disc assembly and relief valve must be replaced as soon as possible. The rupture disc assembly is a one-time-use item.

Pressure switches and gauges can be reused after verifying proper operation. The rupture disc assembly and pressure-relief valve must be isolated and pumped out to zero pressure before removing the pressure gauge or switch.

**These rupture disc assemblies are not for liquid applications, nor are they applicable to differential relief valves to a lower pressure vessel.**

## INSTALLATION DIMENSIONS

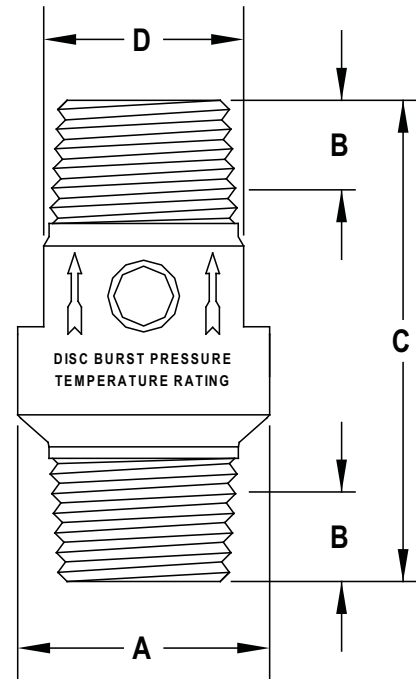

CAT NO	CONNECTION SIZE (MPT x MPT) NPT Taper	DIMENSIONS			
		A	B (Typical Thread Eng'mt)	C	D (Wrench Flats)
RDA1	1/2" x 1/2"	1.40" 36mm	0.53" 13mm	2.67" 68mm	1-1/8" 28mm
RDA2	3/4" x 3/4"	1.40" 36mm	0.55" 14mm	2.67" 68mm	1-1/8" 28mm
RDA4	1" x 1"	2.23" 57mm	0.66" 17mm	4.30" 109mm	1-3/4" 46mm
RDA5	1-1/4" x 1-1/4"	2.23" 57mm	0.68" 17mm	4.30" 109mm	1-3/4" 46mm

## CAUTION

Hansen rupture disc assemblies (RDAs) are for refrigeration systems only. These instructions and related safety precautions must be read completely and understood before selecting, using, or servicing these RDAs. Only knowledgeable, trained refrigeration technicians should install, operate, or service these RDAs. Stated temperature and pressure limits should not be exceeded. Components should not be removed from the system or the system opened unless the system has been evacuated to zero pressure. See also Safety Precautions in the current List Price Bulletin and the Safety Precautions Sheet supplied with this product. Escaping refrigerant can cause injury, especially to the eyes and lungs.

## PRESSURE SWITCHES

Hansen pressure switches provide an electrical indication that a rupture disc has burst and that a relief valve has discharged, or presence of pressure of 25 psi. The pressure-relief valve will re-seat after discharging while the rupture disc remains open. The pressure switch will maintain the signal until a new rupture disc is installed and the pressure is reduced to zero.

### IMPORTANT

There are no user-serviceable parts in the pressure switch. If the switch indicates "burst," the rupture disc assembly and relief valve must be replaced as soon as possible. Pressure switches can be reused after verifying proper operation while a rupture disc assembly is a one-time-use item. The rupture disc assembly and pressure-relief valve must be isolated and pumped out to zero pressure before removing the pressure gauge or switch.

### INSTALLATION

To install switches, use a suitable wrench on the flats of the body and install in place with the proper thread sealant being careful not to have excess sealant fall in to rupture disc assembly. For electrical wiring, refer to wiring diagram and to the specifications for switch ratings.

### SPECIFICATIONS

Set Pressure: 25 psi (1.7 bar), Rising

Switch: SPDT, 5A@120/240 V AC, 12/24V DC

Diaphragm Material: Buna-N

Ambient Temperature Range: -20°F to +125°F (-29°C to +52°C)

Safe Working Pressure (Body): 400 psig (28 bar)

NEMA 4X (IP65)

DIN Connector With 1/2" Conduit Connection

Connection Side Port: 1/8" NPT Connection

Approvals: UL and CSA Recognized, CE

## INSTALLATION DIMENSIONS

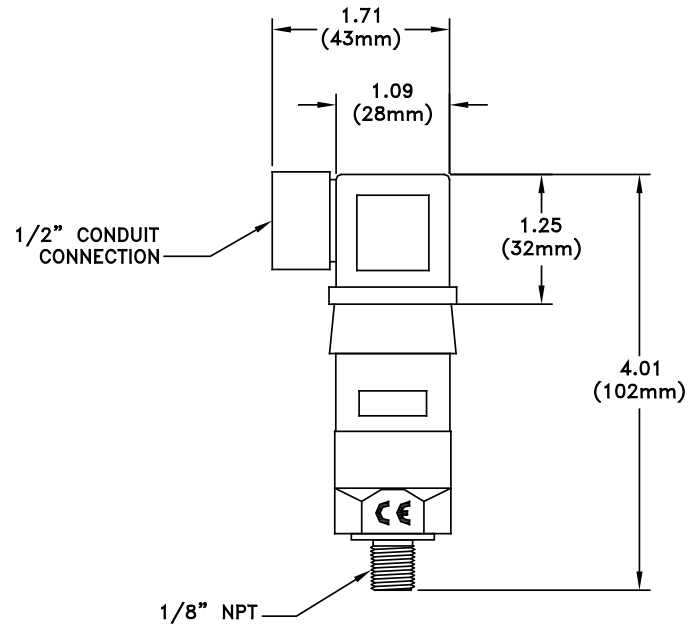

### DIN PLUG WIRING CODE

#### Terminal Number

- #1 Common (C)
- #2 Normally Closed (NC)
- #3 Normally Open (NO)
- #4 Ground

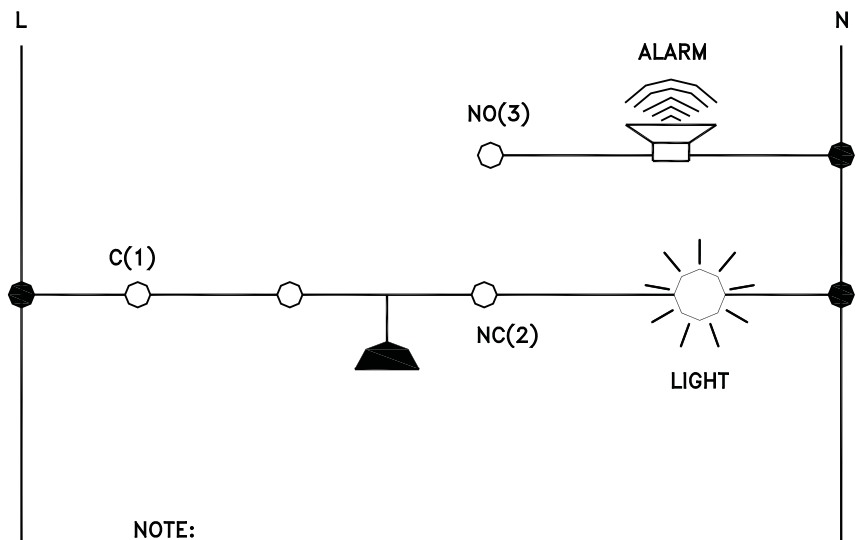

NOTE:  
LIGHT INDICATES ALL DEVICES  
IN SERIES ARE GOOD.

## PRESSURE GAUGES

These special gauges are designed specifically for use with Hansen rupture disc assemblies.

The 2" (50 mm) diameter face has an easy-to-read "OK/burst" display. The green "OK" range is from 0 to 15 psig (0 to 1 bar). When normal pressure is less than 15 psig, the "Tell Tale" indicates the occurrence of pressure, especially useful on vacuum side of refrigeration systems.

The ambient temperature range for these gauges is +32°F to +125°F (0°C to +52°C) and they have a safe working pressure of 400 psig (28 bar). Contact Hansen for applications below +32°F (0°C) ambient temperature.

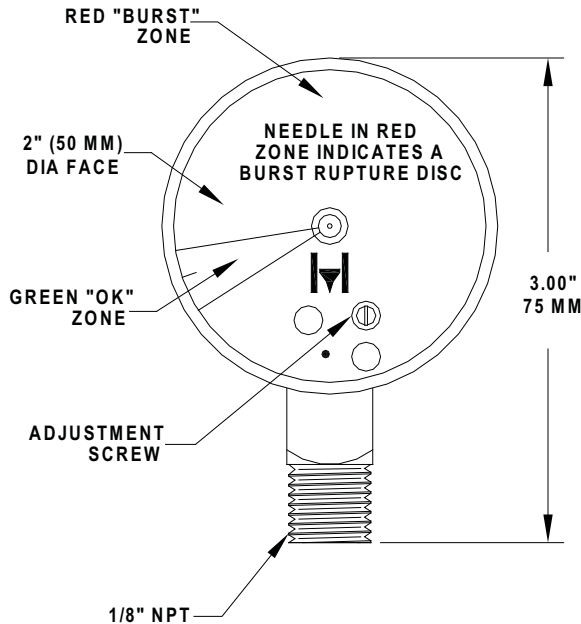

## ORDERING INFORMATION

To Order: Specify catalog number, pressure setting, and pressure gauge (HG25) or switch (HPS). A pressure gauge or switch is required by code.

## RUPTURE DISCS AND ACCESSORIES

CAT NO	CONNECTION SIZE (MPT X MPT)	PRESSURE SETTING
RDA1	1/2" x 1/2"	150, 250, 300 & 400 psig
RDA2	3/4" x 3/4"	150, 250, & 300 psig
RDA4	1" x 1"	150, 250 & 300 psig
RDA5	1-1/4" x 1-1/4"	150, 250 & 300 psig
ACCESSORIES		
HPS	Pressure Switch, 1/8" NPT	
HG25	Pressure Gauge, 1/8" NPT	

Use a rupture disc assembly with the same or lower pressure setting as the pressure relief valve.

## WARRANTY

Rupture disc assemblies, pressure switches, and gauges are guaranteed for one year F.O.B. our plant. No consequential damages or field labor is included.

## IMPORTANT SAFETY WARNING

Hansen Technologies Corporation does not guarantee rupture disc life. It is critical that rupture discs be routinely monitored to determine that no refrigerant has leaked beyond the disc. Slow leakage of refrigerant beyond the rupture disc creates a differential pressure that can double the bursting point of the rupture disc and subject the pressure vessel to elevated pressures. This creates a hazardous condition and in the extreme case could result in loss of human life.

In addition to routine monitoring, it is also recommended that rupture discs be changed annually by qualified industrial refrigeration service personnel.

# HANSEN

Hansen Technologies Corporation  
6827 High Grove Boulevard  
Burr Ridge, Illinois 60527 USA

Tel: 630.325.1565 Fax: 630.325.1572 Toll: 800.426.7368

Email: info@hantech.com Web: www.hantech.com

USA · Asia · Europe · India · Latin America · Middle East

© 2008 Hansen Technologies Corporation