

# FACT SHEET

## XCH-100 Series – Vernier Cables

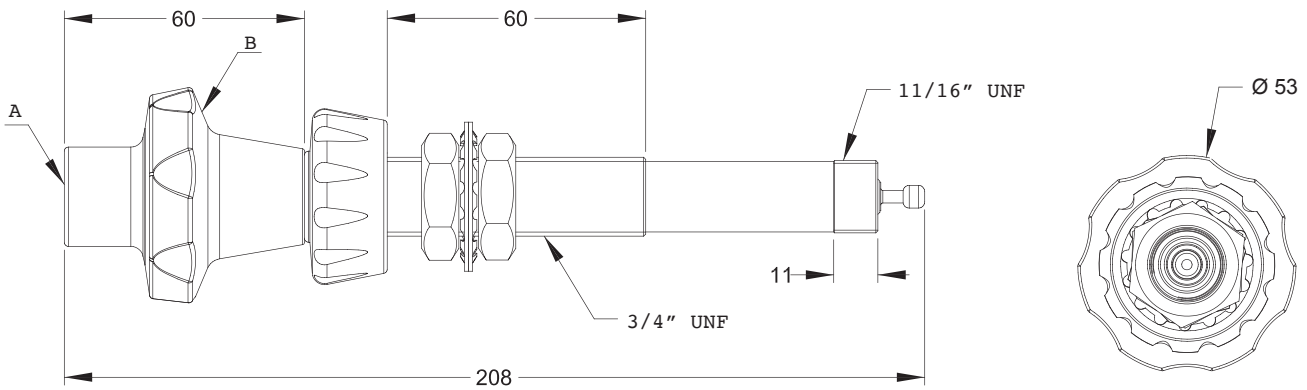

Please refer to V3 cable end dimensions for 50mm & 75mm cable travels on the bulkhead and clamp configurations

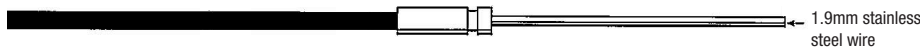

### Key Features

- Material : Brass
- Quick Disconnect type.
- Max. Travel = 76mm
- Max. Load = 30 Kgf
- All Dimensions are in mm.
- Knob Color :-  
A = Red  
B = Black

Cable Family	Cable Rod	End Type	Cable Travel	Base Part No.
XCH-100	OPEN	Threaded	75mm	251
XCH-100	OPEN	Grooved	75mm	252
XCH-100	10-32 unf	Threaded	50mm	351
XCH-100	10-32 unf	Grooved	50mm	354
XCH-100	10-32 unf	Threaded	75mm	351
XCH-100	10-32 unf	Grooved	75mm	354

### Cable Measurement

- When measuring an XCH-100 cable with exposed wire, measure from the base where the vernier head mounts to the tip of the mounting hub where the core is exposed and round up to the nearest 250mm increment.
- When measuring an XCH-100 cable with a rod and sleeve, measure from the base where the vernier head mounts to the tip of the rod and round up to the nearest 250mm increment.
- EXAMPLE: 351075-0100 XCH-100 cable with 75mm travel 1.00 overall length

### Part Numbering System

Base Part No.	Travel in MM	Cable Length in CM
251	050=50mm	Place 0's in the first two positions if less than 1.00 metre.
252	075 = 75mm	
351		
354		